

Johnson Residence - Asbestos Removal

CREATED ON
2023-04-14

LOCATION
16 Kirkgate
HPA 1PA Ripon
North Yorkshire
United Kingdom

Total area 3455.22 sq ft	Floors 3	Rooms 19	Bathrooms 3.1
------------------------------------	--------------------	--------------------	-------------------------

Photos



Photo 1



Photo 2



Photo 3



Photo 4



Photo 5

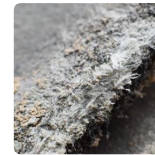

Photo 6



Photo 7



Photo 8

Asbestos Removal Site Form

General Site Details

Name Site Owner
B. Johnson

Date of Inspection
April 20, 2023

Removal Site Address
16 Kirkgate, Ripon, North Yorkshire, UK

State of removal during inspection
Preperation

Removalist's Details

Removalist's Name
Cam Farrington

Johnson Residence - Asbestos Removal

Supervising Hygenists / Air Monitoring
Dean Wills

Is the Removalist licensed?
Yes

Does the Removalist have a supervisor on site?
Yes

Have all employees present been trained appropriately?
No

Are records of training available on site?
Yes

Have all employees on site received appropriate medical examination prior to the work starting?
Yes

Has an asbestos control plan been prepared and is it available on site?
Yes / No

Has a risk assessment/audit been prepared?
Yes

Has the results of the risk assessment been made accessible to Health & Safety Representatives for any relevant designated work group?
No

Asbestos Details

Sprayed limpet
Yes

Pipe lagging
Yes

Boiler
Yes

AC Roof
No

AC Pipe
Yes

AC Sheet
No

Johnson Residence - Asbestos Removal

Vinyl Floor/wall tiles

Yes

Fire door

No

Pump/Valve packing

No

Asbestos Form

Friable

Yes

Non-Friable

Yes

Are appropriate barriers and signs set up?

Yes

Is an industrial HEPA filtered vacuum cleaner available on site?

Yes

Have emergency exits been identified and evacuation plans disseminated to employees?

No

Can the removalist locate appropriate fire extinguishers and are they appropriately placed?

Yes / Yes

Is there sufficient protective clothing and respirators?

Yes

Are respirators used, in accordance with the Worksafe Code of Practice for the Safe Removal of Asbestos?

Yes

Are respirators appropriately stored when not in use?

Yes

Are respirators cleaning and servicing facilities available?

No

Can employees, at random, demonstrate positive and negative fit checks?

Yes

Are appropriate decon units in use?

Yes

Johnson Residence - Asbestos Removal

Is the enclosure and decon units drainage filtered (i.e. pump box)?

Yes

Is a hot water unit for personal washing connected to the decon units?

No

Is the clean end of the decontamination unit satisfactorily clean?

Yes

Has the enclosure had a satisfactory smoke test (or visual inspection equivalent) prior to commencing the removal?

Yes

Is there material on site for spraying surfaces with PVA or a similar solution?

Yes

Is there a log book on site for the following equipment?

Negative air units, Compressors, Vacuum Cleaners or Respirators

Yes

If so, please list the applicable equipment and which ones are missing.

Vacuum cleaners & ventilators.

Are sufficient Asbestos waste containers and leak proof metal storage bins or containers on site?

Yes

Are these containers appropriately secured?

Yes

Are these containers appropriately identified/labeled?

Yes

Are First Aid arrangements satisfactory?

Yes

Is air monitoring taking place?

No

Is laundering of non-disposable clothing conducted on site?

No

If disposable clothing is used, is it all being bagged as asbestos waste?

Yes

Is a brush, high pressure water jet, power tool or similar means being used to remove asbestos or asbestos containing materials in an area that is not completely enclosed and controlled for asbestos removal purposes?

Yes

Johnson Residence - Asbestos Removal

Has all equipment that is being used, or is to be used, been assessed by the removalist for associated hazards, potential risks and appropriate controls implemented?

Yes

Has the removalist provided fall protection for employees required to work on roofs?

Yes

Have or will clearance air monitoring results be completed?

Yes

Have or will surfaces been sprayed with PVA or similar water based paint?

Yes

Has or will the removal area be satisfactorily cleaned (eg, scaffolding, structural, steel, walkways and floor surfaces)?

Yes

Has or will any exposed asbestos been sealed?

Yes

Is any person smoking in the area where asbestos removal is being carried out?

No

Johnson Residence - Asbestos Removal

16 Kirkgate, HPA 1PA Ripon, North Yorkshire, United Kingdom
TOTAL AREA: 3455.22 sq ft • LIVING AREA: 3186.37 sq ft • FLOORS: 3 • ROOMS: 19



▼ Photos/Johnson Residence - Asbestos Removal

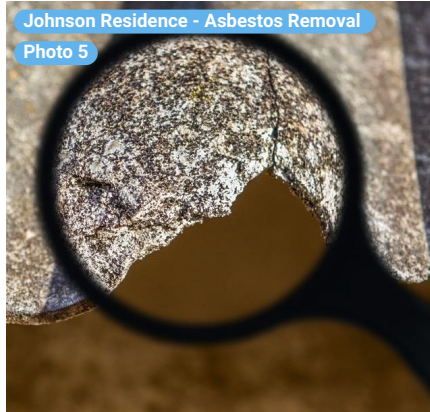
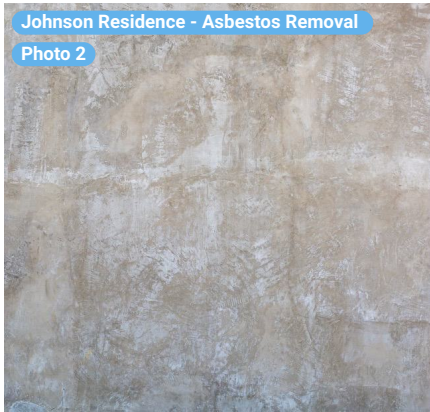
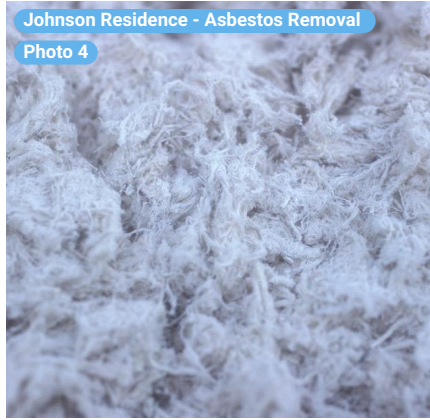
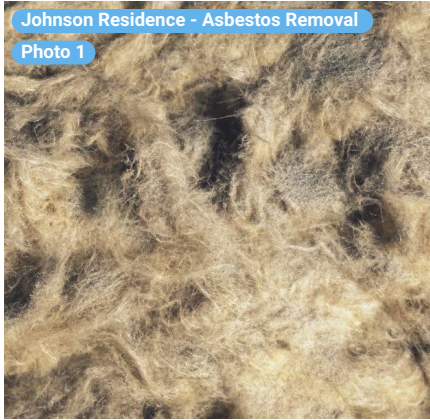

Johnson Residence - Asbestos Removal

16 Kirkgate, HPA 1PA Ripon, North Yorkshire, United Kingdom
 TOTAL AREA: 3455.22 sq ft • LIVING AREA: 3186.37 sq ft • FLOORS: 3 • ROOMS: 19



▼ Ground Floor

TOTAL AREA: 1223.26 sq ft • LIVING AREA: 954.41 sq ft • ROOMS: 6

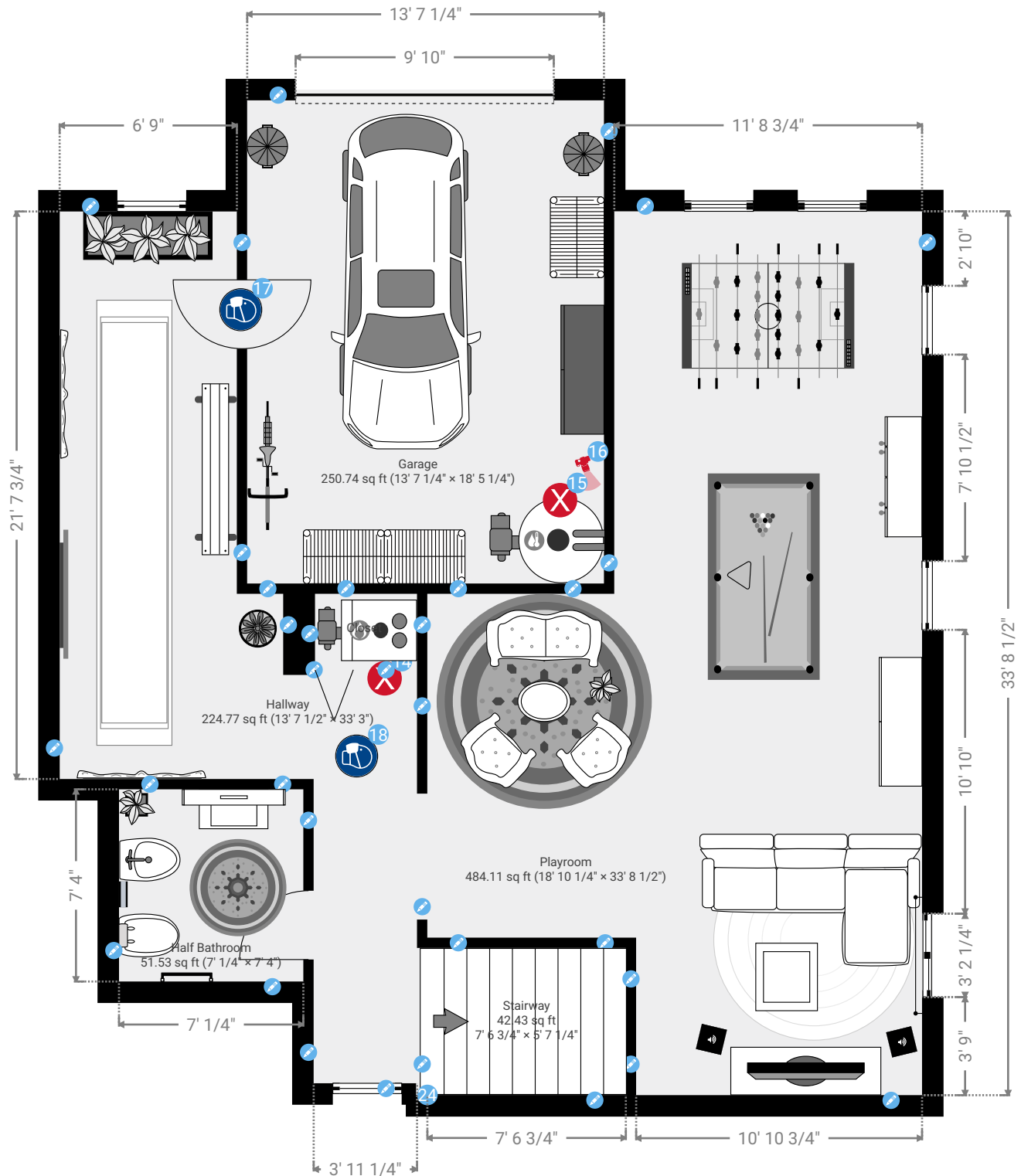

Johnson Residence - Asbestos Removal

16 Kirkgate, HPA 1PA Ripon, North Yorkshire, United Kingdom

TOTAL AREA: 3455.22 sq ft • LIVING AREA: 3186.37 sq ft • FLOORS: 3 • ROOMS: 19



▼ Ground Floor

17 WEAR A MASK

Notes

Do not enter without proper safety equipment



Johnson Residence - Asbestos Removal

16 Kirkgate, HPA 1PA Ripon, North Yorkshire, United Kingdom
TOTAL AREA: 3455.22 sq ft • LIVING AREA: 3186.37 sq ft • FLOORS: 3 • ROOMS: 19



▼ Garage Ground Floor

WIDTH: 18' 5 1/4" • LENGTH: 13' 7 1/4"
AREA: 250.74 sq ft • PERIMETER: 64' 3/4"

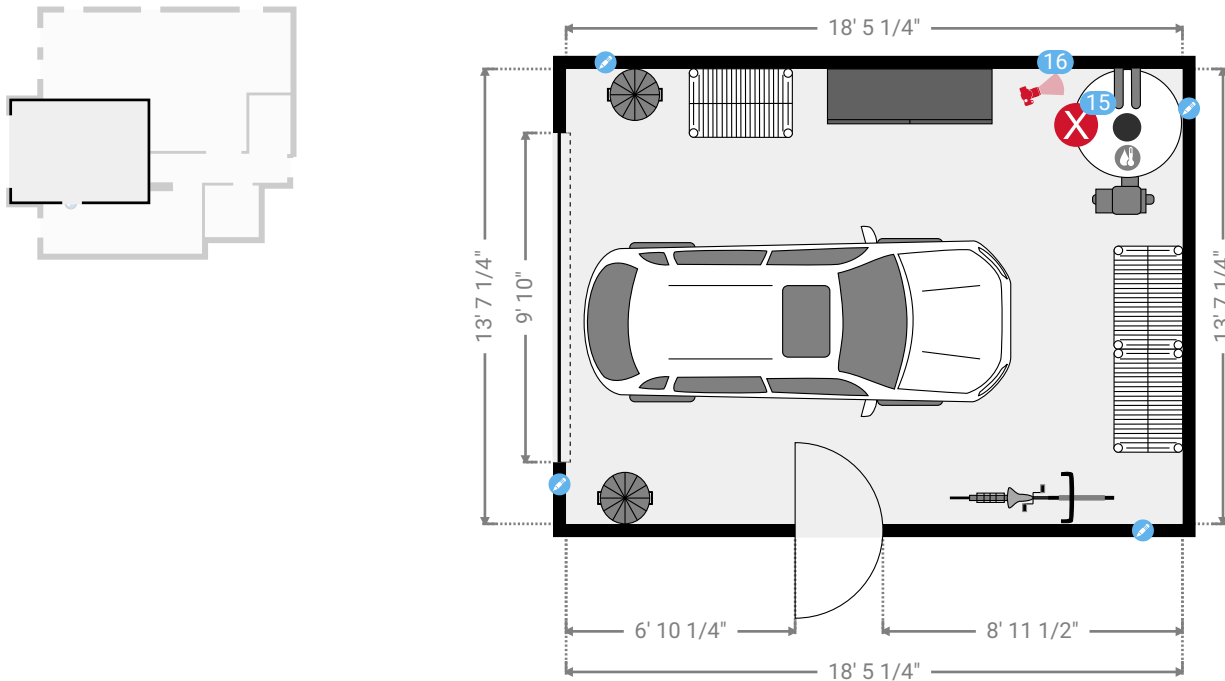

▼ Garage/Ground Floor

15 TO REMOVE

Notes

To be removed due to asbestos insulation around pipes



16 PHOTO

Photo



Johnson Residence - Asbestos Removal

16 Kirkgate, HPA 1PA Ripon, North Yorkshire, United Kingdom
TOTAL AREA: 3455.22 sq ft • LIVING AREA: 3186.37 sq ft • FLOORS: 3 • ROOMS: 19



▼ Photos/Garage



Johnson Residence - Asbestos Removal

16 Kirkgate, HPA 1PA Ripon, North Yorkshire, United Kingdom
 TOTAL AREA: 3455.22 sq ft • LIVING AREA: 3186.37 sq ft • FLOORS: 3 • ROOMS: 19



▼ Half Bathroom Ground Floor

WIDTH: 7' 4" • LENGTH: 7' 1/4"
 AREA: 51.53 sq ft • PERIMETER: 28' 8 3/4"

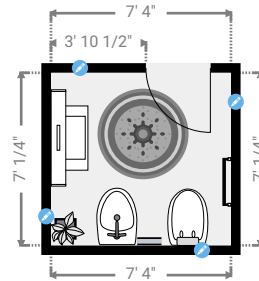
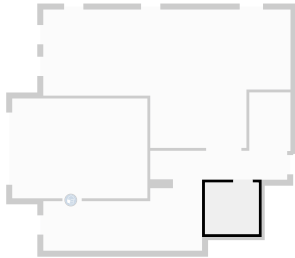

▼ Hallway Ground Floor

WIDTH: 33' 3" • LENGTH: 13' 7 1/2"
 AREA: 224.77 sq ft • PERIMETER: 93' 9 1/4"

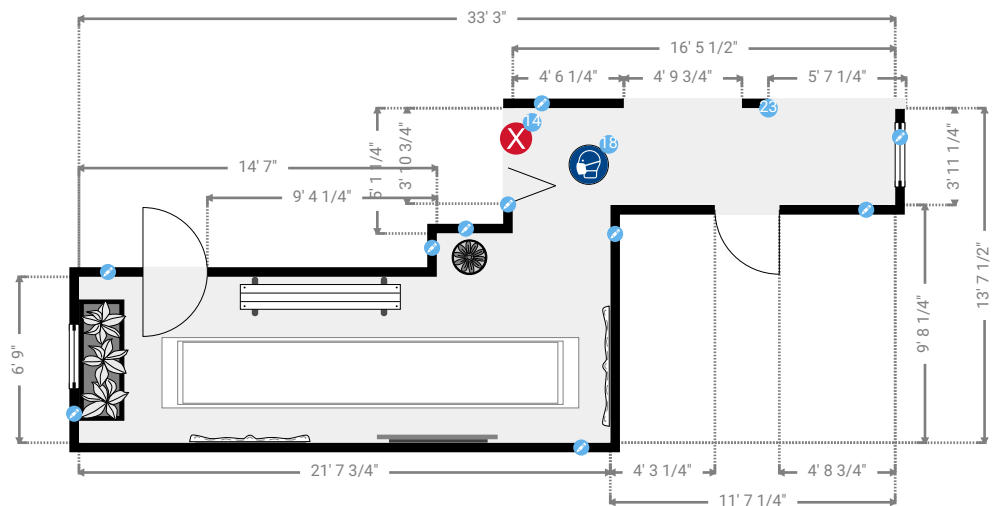
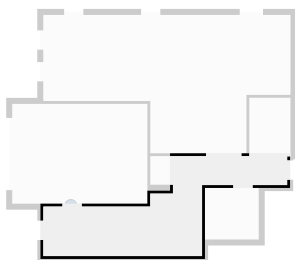

Johnson Residence - Asbestos Removal

16 Kirkgate, HPA 1PA Ripon, North Yorkshire, United Kingdom
TOTAL AREA: 3455.22 sq ft • LIVING AREA: 3186.37 sq ft • FLOORS: 3 • ROOMS: 19



▼ Hallway/Ground Floor

14 TO REMOVE

Notes

Oil furnace is using asbestos insulation - to be removed entirely



18 WEAR A MASK

Notes

Do not enter without proper safety equipment



Johnson Residence - Asbestos Removal

16 Kirkgate, HPA 1PA Ripon, North Yorkshire, United Kingdom
 TOTAL AREA: 3455.22 sq ft • LIVING AREA: 3186.37 sq ft • FLOORS: 3 • ROOMS: 19



▼ Closet Ground Floor

WIDTH: 2' 8 1/2" • LENGTH: 3' 10 3/4"
 AREA: 10.50 sq ft • PERIMETER: 13' 2 1/4"

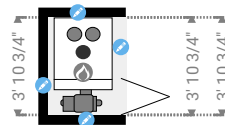
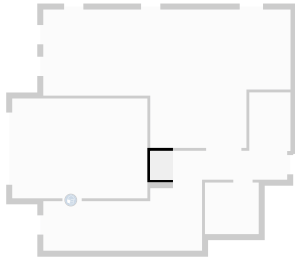

▼ Playroom Ground Floor

WIDTH: 33' 8 1/2" • LENGTH: 18' 10 1/4"
 AREA: 484.11 sq ft • PERIMETER: 105' 1 3/4"

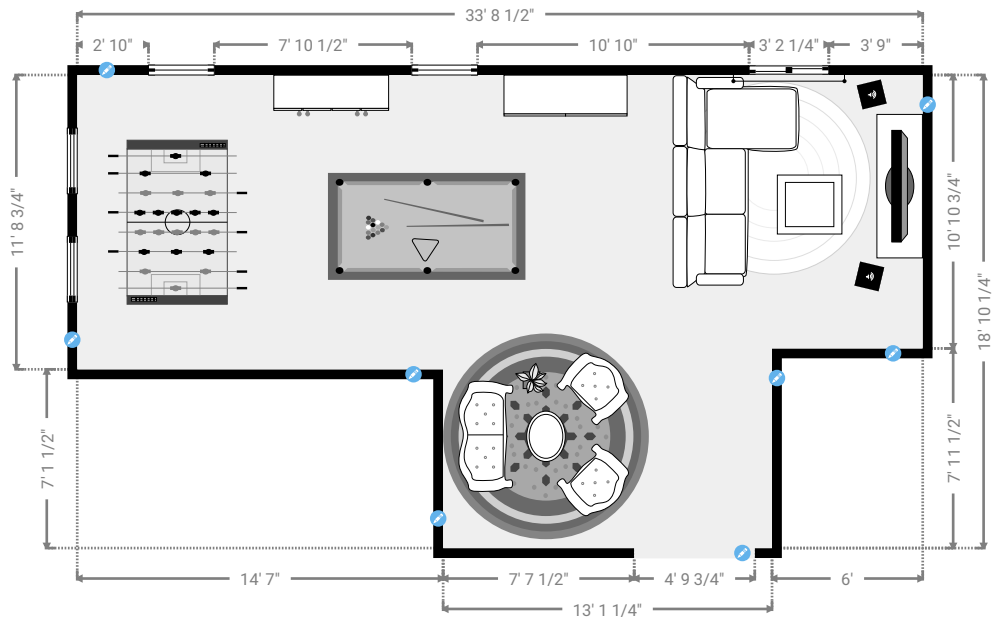
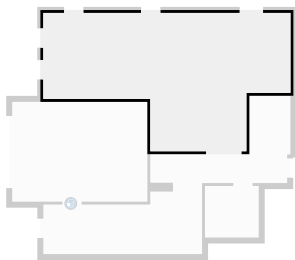

Johnson Residence - Asbestos Removal

16 Kirkgate, HPA 1PA Ripon, North Yorkshire, United Kingdom
TOTAL AREA: 3455.22 sq ft • LIVING AREA: 3186.37 sq ft • FLOORS: 3 • ROOMS: 19



▼ Stairway Ground Floor

WIDTH: 5' 7 1/4" • LENGTH: 7' 6 3/4"
AREA: 42.43 sq ft • PERIMETER: 26' 4 1/4"

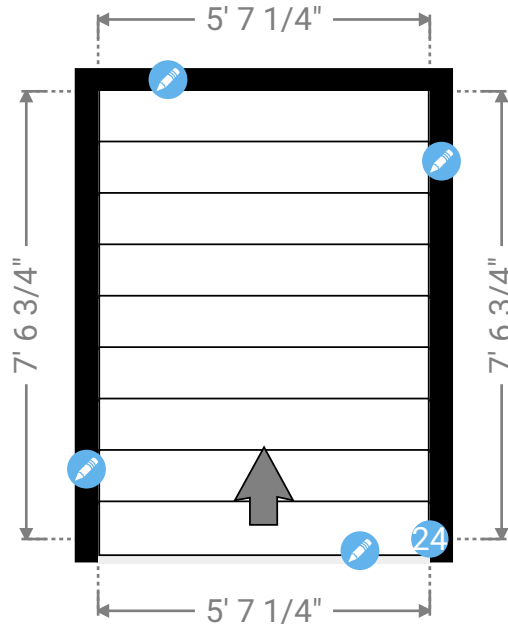
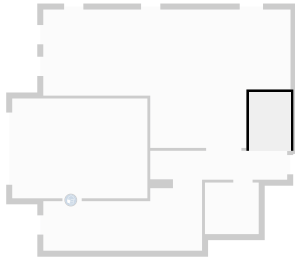

▼ Stairway/Ground Floor

24 OPENING

Height
0



Johnson Residence - Asbestos Removal

16 Kirkgate, HPA 1PA Ripon, North Yorkshire, United Kingdom
 TOTAL AREA: 3455.22 sq ft • LIVING AREA: 3186.37 sq ft • FLOORS: 3 • ROOMS: 19



▼ 1st Floor

TOTAL AREA: 1223.96 sq ft • LIVING AREA: 1223.96 sq ft • ROOMS: 6

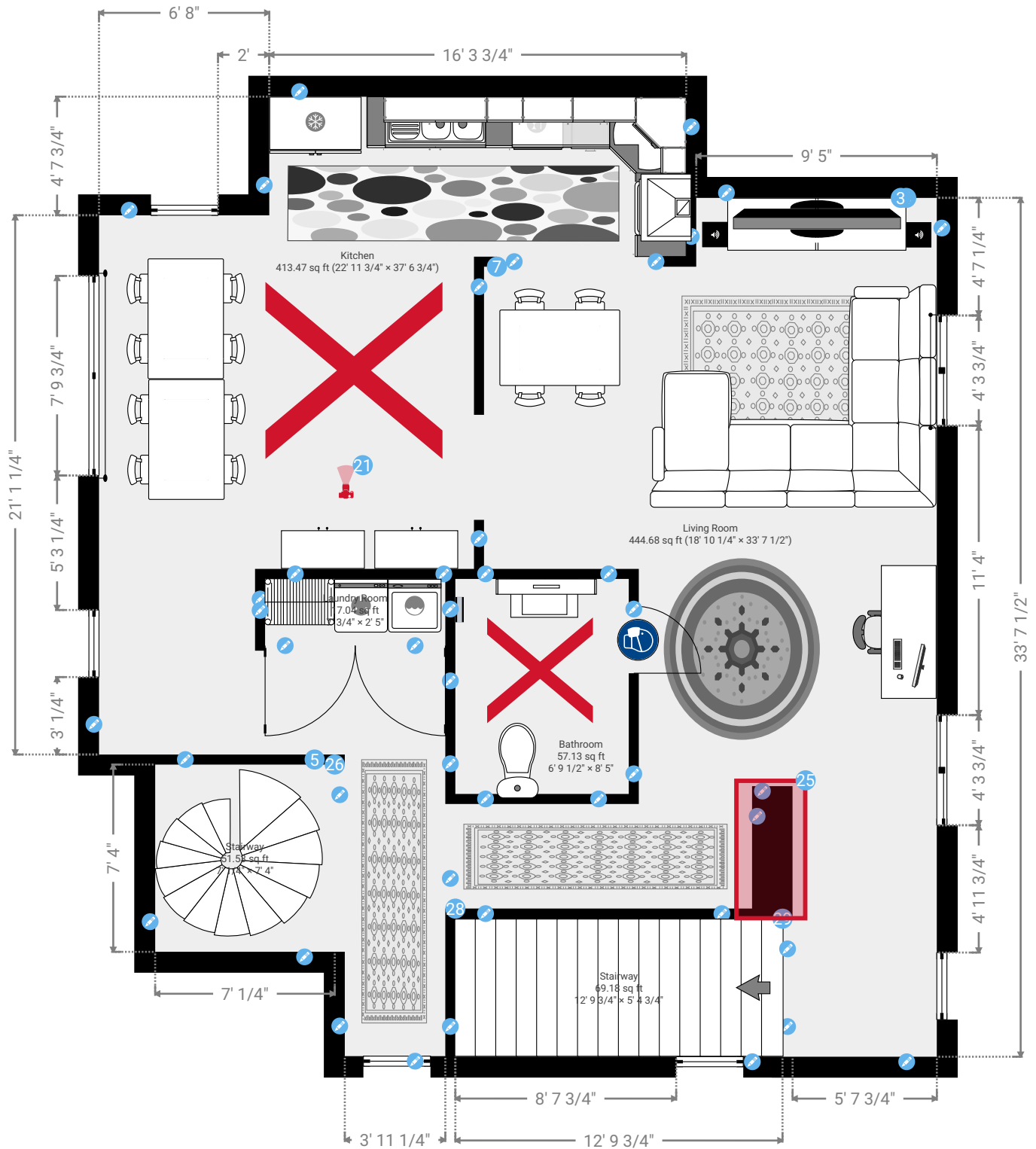

Johnson Residence - Asbestos Removal

16 Kirkgate, HPA 1PA Ripon, North Yorkshire, United Kingdom
TOTAL AREA: 3455.22 sq ft • LIVING AREA: 3186.37 sq ft • FLOORS: 3 • ROOMS: 19



▼ 1st Floor

25 RECTANGLE



Notes

Filler wall support contains asbestos insulation (vermiculite)

Johnson Residence - Asbestos Removal

16 Kirkgate, HPA 1PA Ripon, North Yorkshire, United Kingdom
TOTAL AREA: 3455.22 sq ft • LIVING AREA: 3186.37 sq ft • FLOORS: 3 • ROOMS: 19



▼ Bathroom 1st Floor

WIDTH: 8' 5" • LENGTH: 6' 9 1/2"
AREA: 57.13 sq ft • PERIMETER: 30' 5"

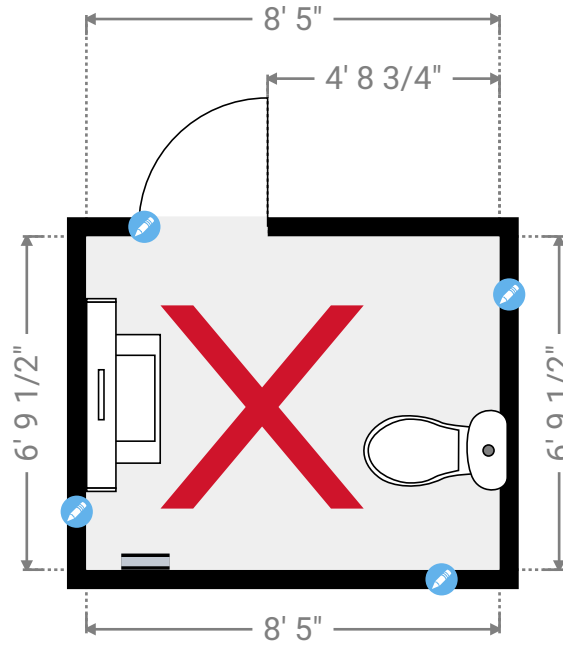
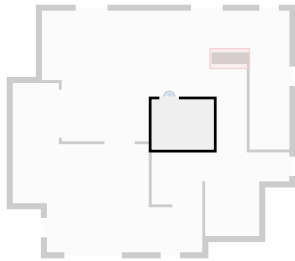

▼ Bathroom/1st Floor

Notes

Damaged vinyl flooring exposing asbestos materials

Johnson Residence - Asbestos Removal

16 Kirkgate, HPA 1PA Ripon, North Yorkshire, United Kingdom
TOTAL AREA: 3455.22 sq ft • LIVING AREA: 3186.37 sq ft • FLOORS: 3 • ROOMS: 19



▼ Photos/Kitchen



Johnson Residence - Asbestos Removal

16 Kirkgate, HPA 1PA Ripon, North Yorkshire, United Kingdom
 TOTAL AREA: 3455.22 sq ft • LIVING AREA: 3186.37 sq ft • FLOORS: 3 • ROOMS: 19



▼ Laundry Room 1st Floor

WIDTH: 2' 5" • LENGTH: 7' 3/4"
 AREA: 17.04 sq ft • PERIMETER: 18' 11 1/4"

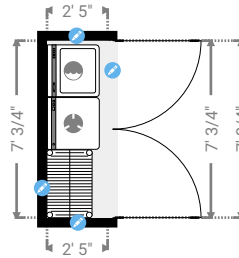
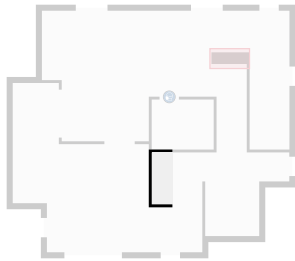

▼ Living Room 1st Floor

WIDTH: 33' 7 1/2" • LENGTH: 18' 10 1/4"
 AREA: 444.68 sq ft • PERIMETER: 126' 7 1/2"

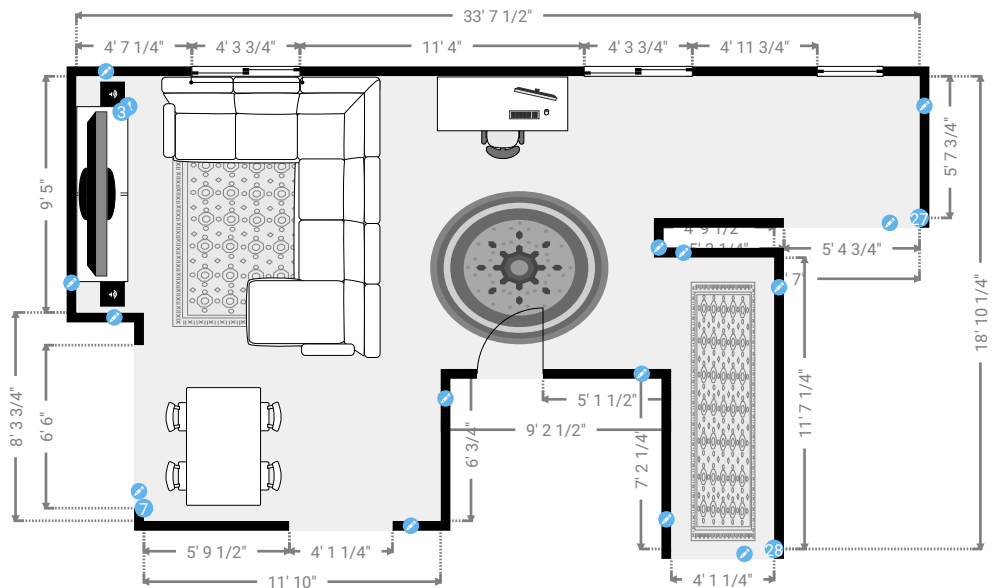
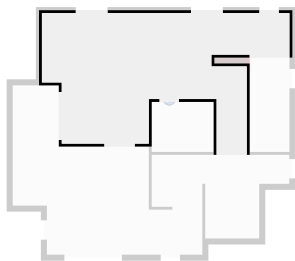

Johnson Residence - Asbestos Removal

16 Kirkgate, HPA 1PA Ripon, North Yorkshire, United Kingdom
TOTAL AREA: 3455.22 sq ft • LIVING AREA: 3186.37 sq ft • FLOORS: 3 • ROOMS: 19



▼ Living Room/1st Floor

3 TV

Height
4' 11"

Distance to Floor
2' 6"



4 BOOKCASE

Height
2' 6"



28 OPENING

Height
0



Johnson Residence - Asbestos Removal

16 Kirkgate, HPA 1PA Ripon, North Yorkshire, United Kingdom
TOTAL AREA: 3455.22 sq ft • LIVING AREA: 3186.37 sq ft • FLOORS: 3 • ROOMS: 19



▼ Stairway 1st Floor

WIDTH: 7' 4" • LENGTH: 7' 1/4"
AREA: 51.53 sq ft • PERIMETER: 28' 8 3/4"

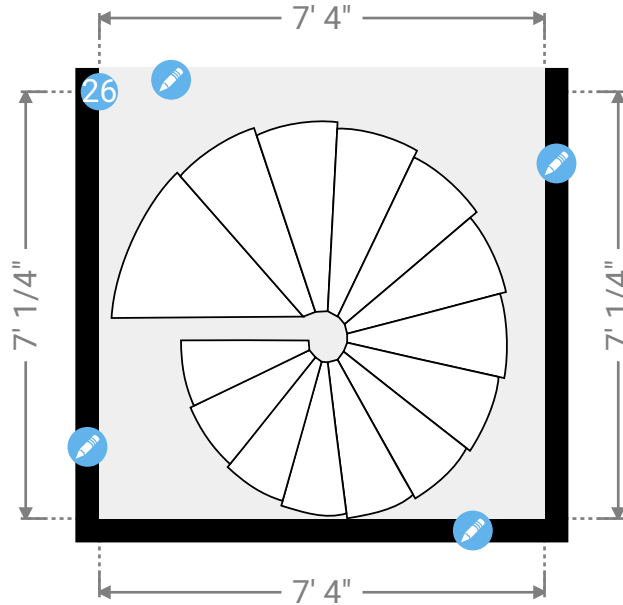
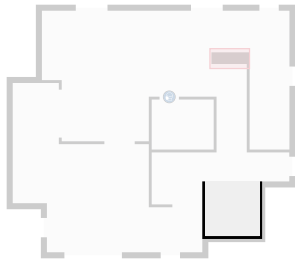

▼ Stairway/1st Floor

26 OPENING

Height
0



Johnson Residence - Asbestos Removal

16 Kirkgate, HPA 1PA Ripon, North Yorkshire, United Kingdom
TOTAL AREA: 3455.22 sq ft • LIVING AREA: 3186.37 sq ft • FLOORS: 3 • ROOMS: 19



▼ Stairway 1st Floor

WIDTH: 5' 4 3/4" • LENGTH: 12' 9 3/4"
AREA: 69.18 sq ft • PERIMETER: 36' 5"

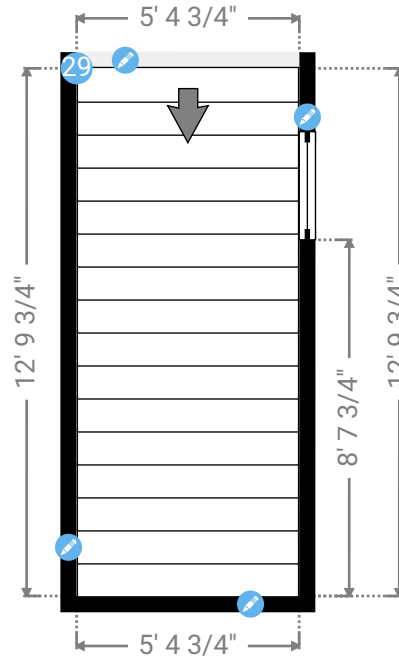
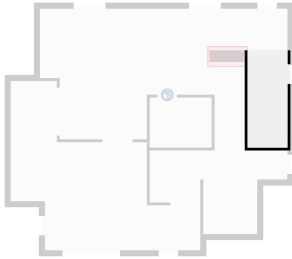

▼ Stairway/1st Floor

29 OPENING

Height
0



Johnson Residence - Asbestos Removal

16 Kirkgate, HPA 1PA Ripon, North Yorkshire, United Kingdom
 TOTAL AREA: 3455.22 sq ft • LIVING AREA: 3186.37 sq ft • FLOORS: 3 • ROOMS: 19



▼ 2nd Floor

TOTAL AREA: 1008.00 sq ft • LIVING AREA: 1008.00 sq ft • ROOMS: 7

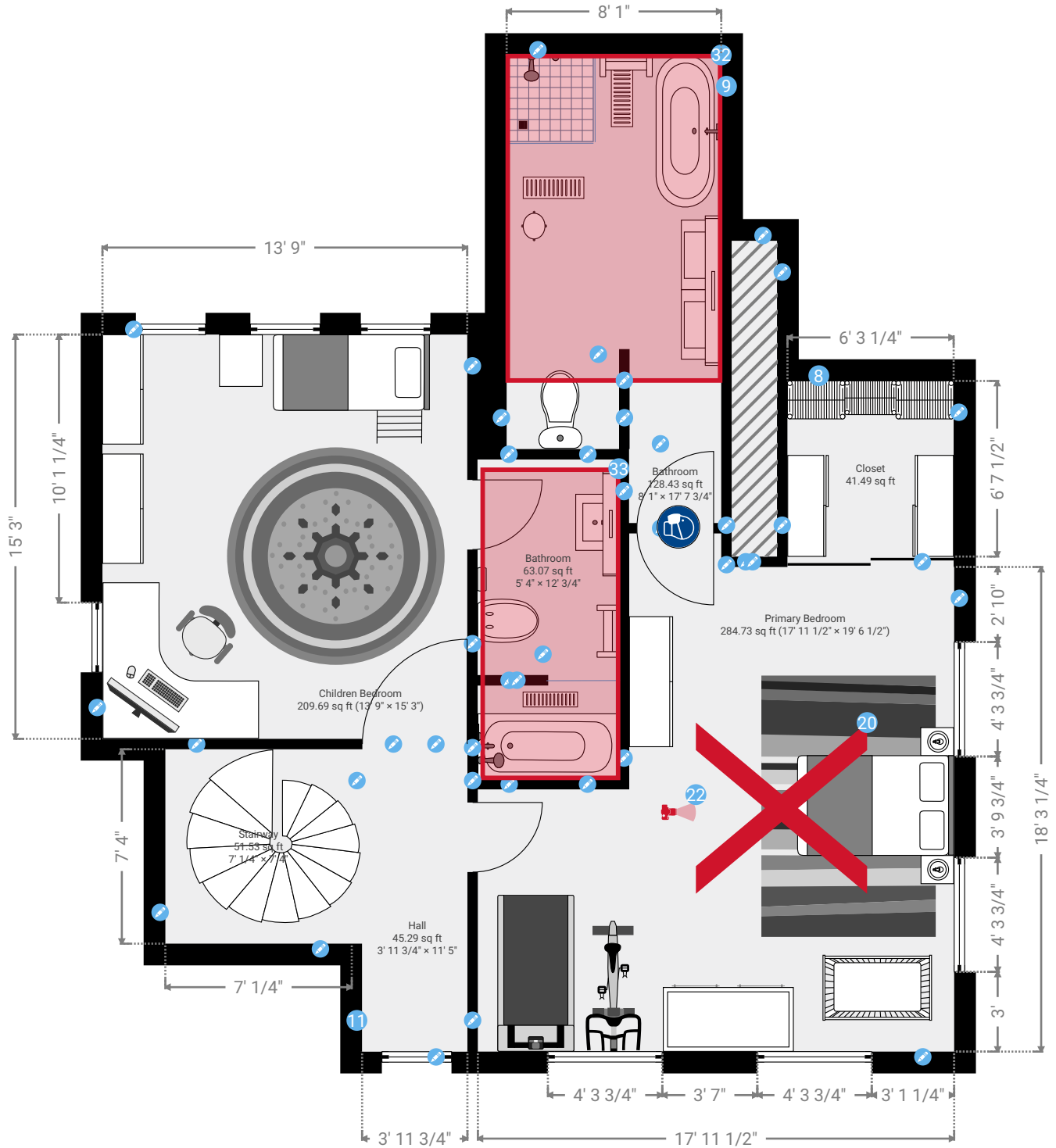

Johnson Residence - Asbestos Removal

16 Kirkgate, HPA 1PA Ripon, North Yorkshire, United Kingdom
TOTAL AREA: 3455.22 sq ft • LIVING AREA: 3186.37 sq ft • FLOORS: 3 • ROOMS: 19



▼ Bathroom 2nd Floor

WIDTH: 17' 7 3/4" • LENGTH: 8' 1"
AREA: 128.43 sq ft • PERIMETER: 59' 3/4"

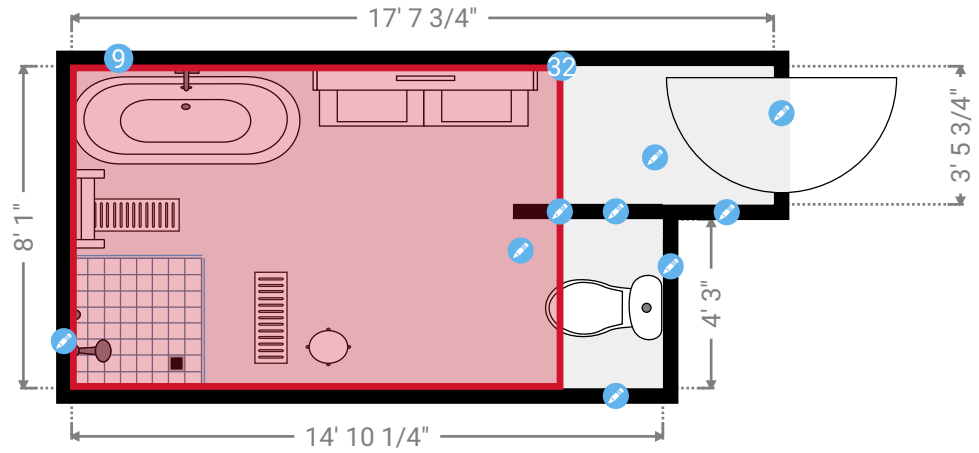
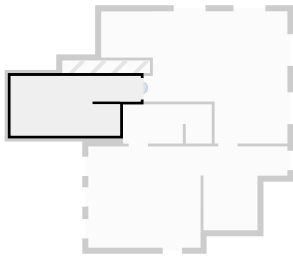

▼ Bathroom/2nd Floor

32 RECTANGLE

Notes

All hot water pipes in primary bath insulated with asbestos based materials



Johnson Residence - Asbestos Removal

16 Kirkgate, HPA 1PA Ripon, North Yorkshire, United Kingdom
TOTAL AREA: 3455.22 sq ft • LIVING AREA: 3186.37 sq ft • FLOORS: 3 • ROOMS: 19



▼ Bathroom 2nd Floor

WIDTH: 12' 3/4" • LENGTH: 5' 4"
AREA: 63.07 sq ft • PERIMETER: 40' 3/4"

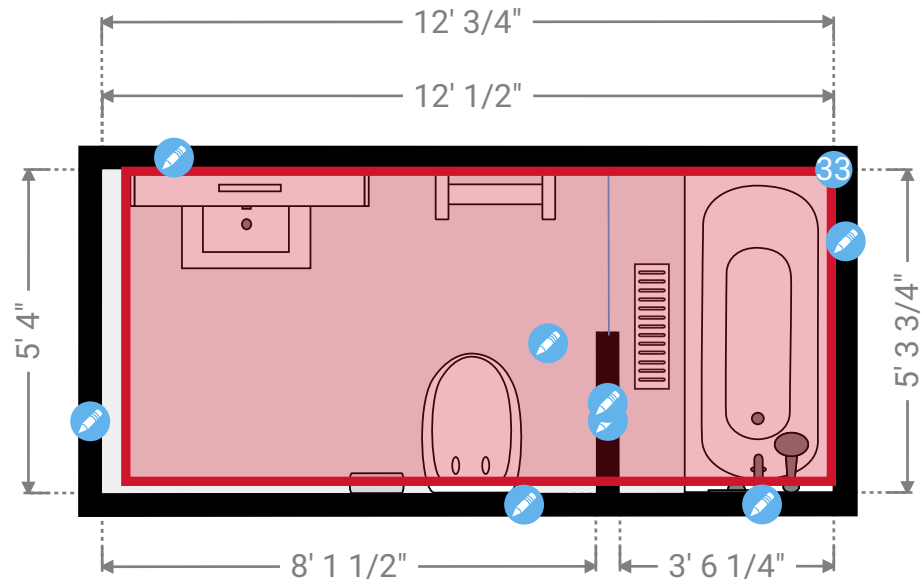
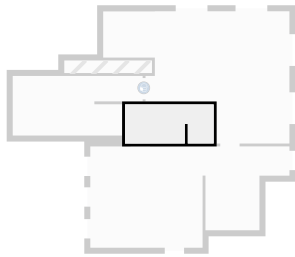

▼ Bathroom/2nd Floor

33 RECTANGLE

Notes

All hot water pipes in primary bath insulated with asbestos based materials



Johnson Residence - Asbestos Removal

16 Kirkgate, HPA 1PA Ripon, North Yorkshire, United Kingdom
 TOTAL AREA: 3455.22 sq ft • LIVING AREA: 3186.37 sq ft • FLOORS: 3 • ROOMS: 19



▼ Children Bedroom 2nd Floor

WIDTH: 15' 3" • LENGTH: 13' 9"
 AREA: 209.69 sq ft • PERIMETER: 58'

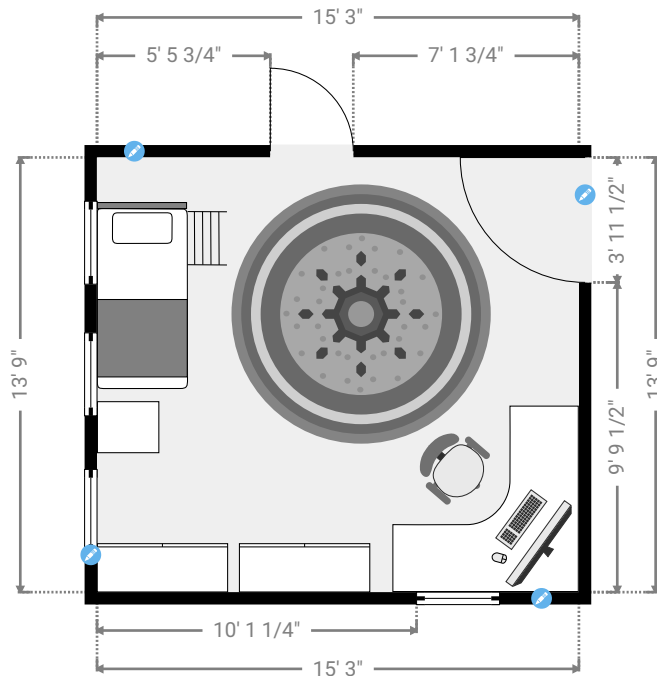
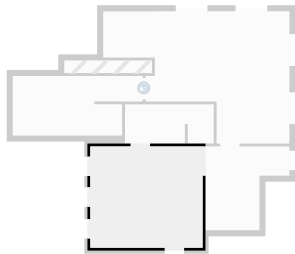

▼ Hall 2nd Floor

WIDTH: 11' 5" • LENGTH: 3' 11 3/4"
 AREA: 45.29 sq ft • PERIMETER: 30' 9"

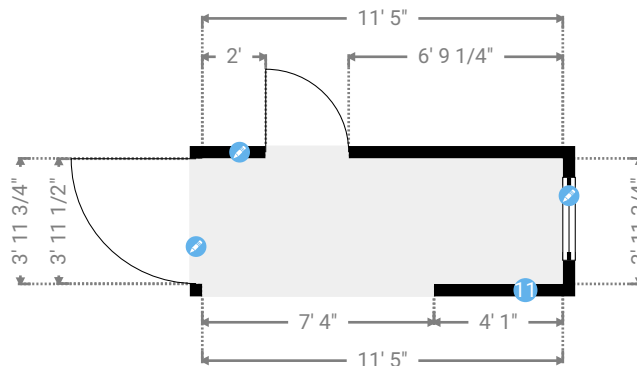
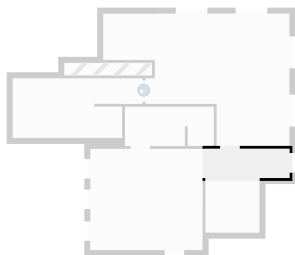

Johnson Residence - Asbestos Removal

16 Kirkgate, HPA 1PA Ripon, North Yorkshire, United Kingdom
 TOTAL AREA: 3455.22 sq ft • LIVING AREA: 3186.37 sq ft • FLOORS: 3 • ROOMS: 19



▼ Primary Bedroom 2nd Floor

WIDTH: 19' 6 1/2" • LENGTH: 17' 11 1/2"
 AREA: 284.73 sq ft • PERIMETER: 75'

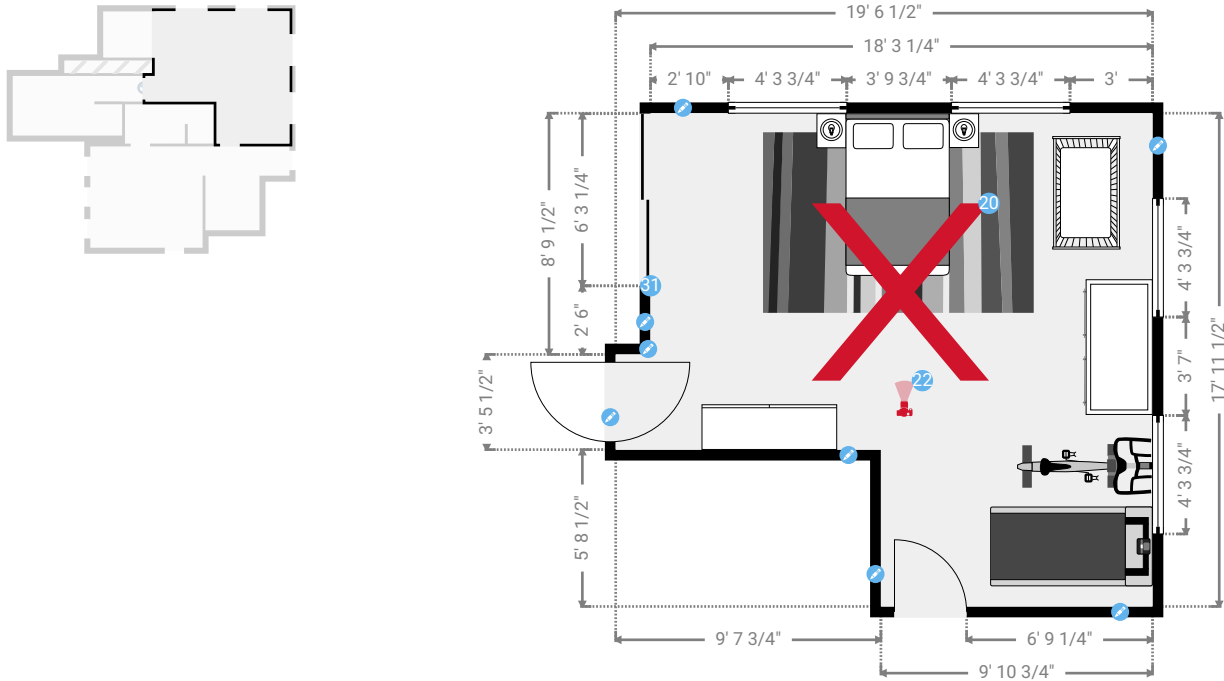

▼ Primary Bedroom/2nd Floor

20 X

Notes

Primary bedroom has asbestos based popcorn ceilings



22 PHOTO

Photo



Johnson Residence - Asbestos Removal

16 Kirkgate, HPA 1PA Ripon, North Yorkshire, United Kingdom
TOTAL AREA: 3455.22 sq ft • LIVING AREA: 3186.37 sq ft • FLOORS: 3 • ROOMS: 19



▼ Photos/Primary Bedroom

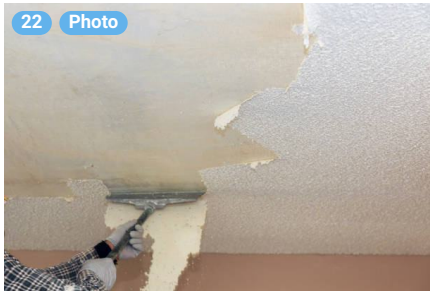

Johnson Residence - Asbestos Removal

16 Kirkgate, HPA 1PA Ripon, North Yorkshire, United Kingdom
TOTAL AREA: 3455.22 sq ft • LIVING AREA: 3186.37 sq ft • FLOORS: 3 • ROOMS: 19



▼ Closet 2nd Floor

WIDTH: 6' 7 1/2" • LENGTH: 6' 3 1/4"
AREA: 41.49 sq ft • PERIMETER: 25' 9 1/4"

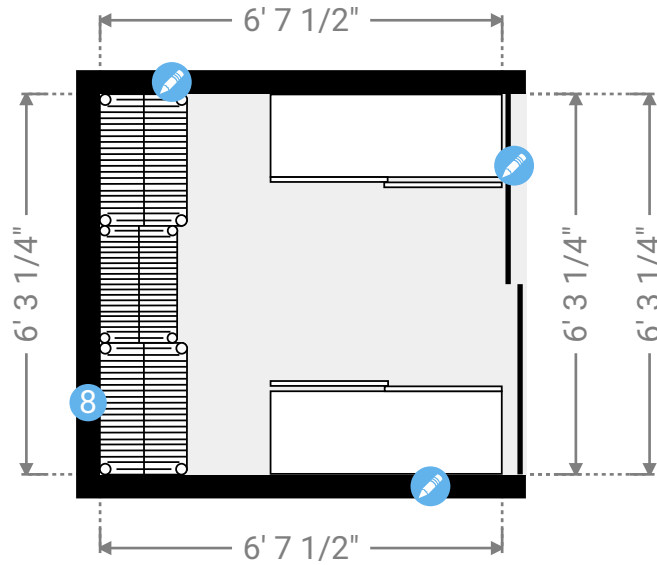
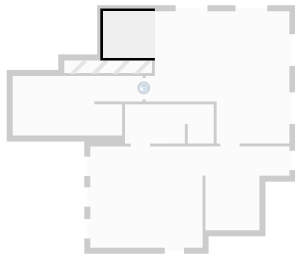

▼ Stairway 2nd Floor

WIDTH: 7' 4" • LENGTH: 7' 1/4"
AREA: 51.53 sq ft • PERIMETER: 28' 8 3/4"

